

CASE STUDY & PASSAGE BASED QUESTIONS

For CBSE 2027 Exams Class 10 - Mathematics

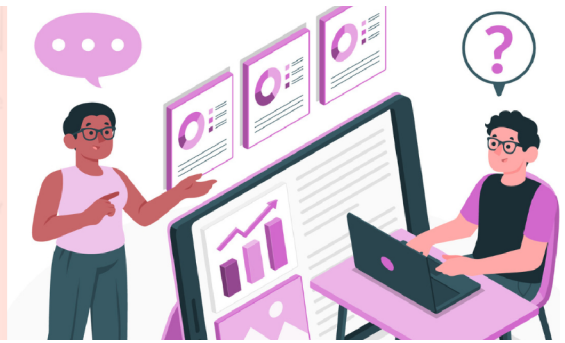

Chapter-01 Real Numbers

Q01. Khushi wants to organize her birthday party. Being health conscious, she decided to serve only fruits in her birthday party. She bought 36 apples and 60 bananas and decided to distribute fruits equally among all.

Based on the above information, answer the following questions.

- How many guests Khushi can invite at the most?
- How many apples and bananas will each guest get?
- If Khushi decides to add 42 mangoes, how many guests Khushi can invite at the most?

OR

- If the cost of 1 dozen of bananas is ₹60, the cost of 1 apple is ₹15 and cost of 1 mango is ₹20, find the total amount spent on 60 bananas, 36 apples and 42 mangoes.

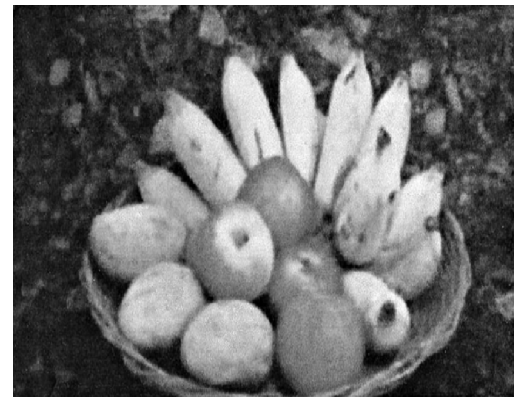

Chapter-02 Polynomials

Q01. Rainbow is an arch of colours that is visible in the sky after rain or when water droplets are present in the atmosphere. The colours of the rainbow are generally red, orange, yellow, green, blue, indigo and violet. Each colour of the rainbow makes a parabola. We know that any quadratic polynomial $p(x) = ax^2 + bx + c$, ($a \neq 0$) represents a parabola on the graph paper.

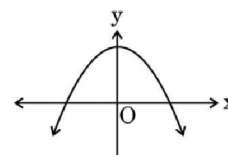

Based on the above, answer the following questions.

- The graph of $y = f(x)$ is shown in the figure. Write the number of zeroes of the curve.
- If the graph of a rainbow does not intersect the x-axis but intersects y-axis at one point, then how many zeroes will it have?
- If a rainbow is represented by the quadratic polynomial $p(x) = x^2 + (a+1)x + b$, whose zeroes are 2 and -3 , find the value of a and b .

OR

- The polynomial $x^2 - 2x - (7p+3)$ represents a rainbow. If -4 is a zero of it, find the value of p .

Q02. In a pool at an aquarium, a dolphin jumps out of the water travelling at 20 cm per second. Its height above water level after t seconds is given by $h = 20t - 16t^2$.

Based on above information, answer the following questions.

- (i) Find zeroes of polynomial $p(t) = 20t - 16t^2$.
- (ii) Which of the following types of graph represents $p(t)$?

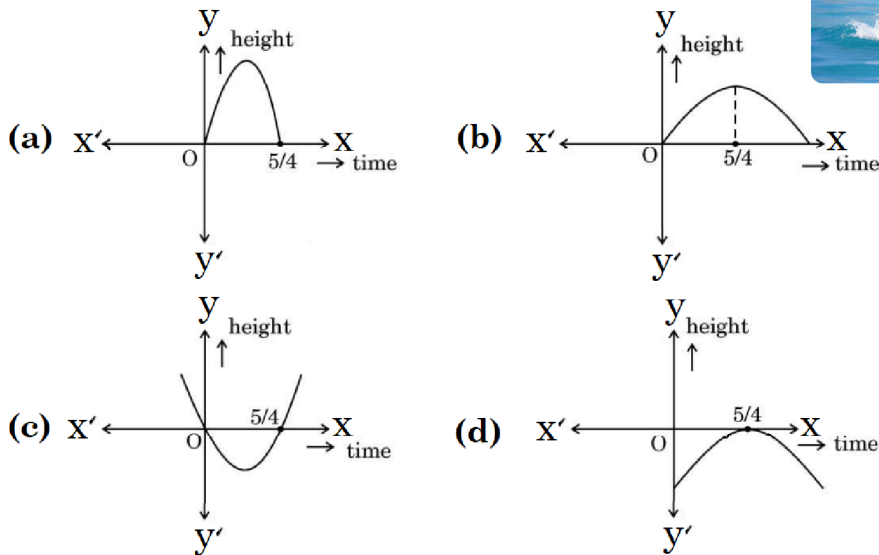

- (iii) What would be the value of h at $t = \frac{3}{2}$? Interpret the result.

OR

- (iii) How much distance has the dolphin covered before hitting the water level again?

Chapter-03 Pair of Linear Equations in Two Variables

Q01. Lokesh, a production manager in Mumbai, hires a taxi everyday to go to his office. The taxi charges in Mumbai consists of a fixed charges together with the charges for the distance covered. His office is at a distance of 10 km from his home. For a distance of 10 km to his office, Lokesh paid ₹105. While coming back home, he took another route. He covered a distance of 15 km and the charges paid by him were ₹155.

Based on the above information, answer the following questions.

- (i) What are the fixed charges?
- (ii) What are the charges per km?
- (iii) If fixed charges are ₹20 and charges per km are ₹10, then how much Lokesh have to pay for travelling a distance of 10 km?

OR

- (iii) Find the total amount paid by Lokesh for travelling 10 km from home to office and 25 km from office to home. [Fixed charges and charges per km are as in (i) & (ii)].



Q02. A coaching institute of Mathematics conducts classes in two batches I and II and fees for rich and poor children are different. In batch I, there are 20 poor and 5 rich children, whereas in batch II, there are 5 poor and 25 rich children. The total monthly collection of fees from batch I is ₹9000 and from batch II is ₹26000. Assume that each poor child pays ₹ x per month and each rich child pays ₹ y per month.

Based on the above information, answer the following questions.

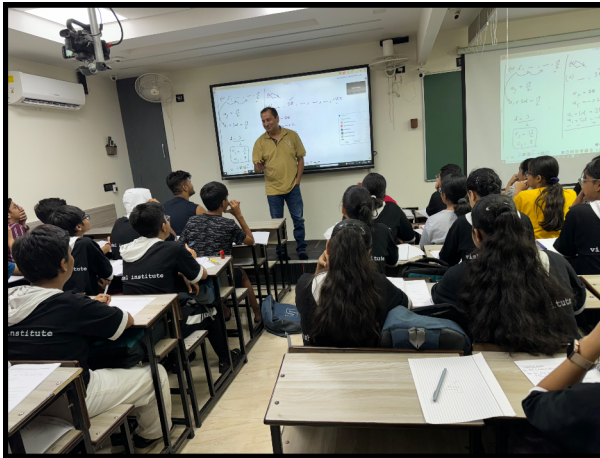

- (i) Represent the information given above in terms of x and y .
- (ii) Find the monthly fee paid by a poor child.

OR

- (ii) Find the difference in the monthly fee paid by a poor child and a rich child.
- (iii) If there are 10 poor and 20 rich children in batch II, what is the total monthly collection of fees from batch II?

Q03. Two schools 'P' and 'Q' decided to award prizes to their students for two games of Hockey ₹ x per student and Cricket ₹ y per student. School 'P' decided to award a total of ₹9500 for the two games to 5 and 4 students respectively; while school 'Q' decided to award ₹7370 for the two games to 4 and 3 students respectively.

Based on the above information, answer the questions given below.

- (i) Represent the given information algebraically (in terms of x and y).
- (ii) What is the prize amount for hockey?

OR

- (ii) Prize amount on which game is more and by how much?
- (iii) What will be the total prize amount if there are 2 students each from two games?



Chapter-04 Quadratic Equations

Q01. While designing the school year book, a teacher asked the student that the length and width of a particular photo is increased by x units each to double the area of the photo. The original photo is 18 cm long and 12 cm wide.

Based on the above information, answer the following questions.

- (i) Write an algebraic equation depicting the above information.
- (ii) Write the corresponding quadratic equation in standard form.
- (iii) What should be the new dimensions of the enlarged photo?

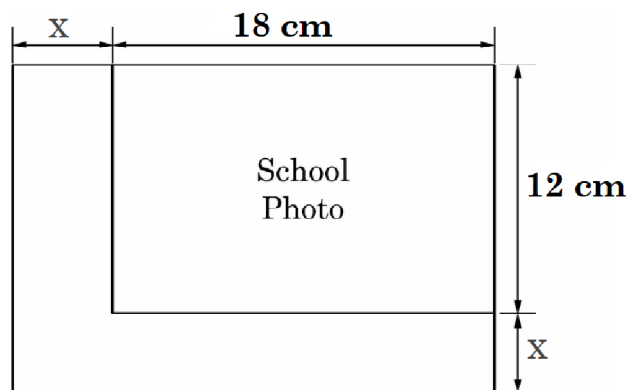

OR

- (iii) Can any rational value of x make the new area equal to 220 cm^2 .

Q02. A rectangular floor area can be completely tiled with 200 square tiles. If the side length of each tile is increased by 1 unit, it would take only 128 tiles to cover the floor.

- (i) Assuming the original length of each side of a tile be x units, make a quadratic equation from the above information.
- (ii) Write the corresponding quadratic equation in standard form.
- (iii) Find the value of x , the length of side of a tile by factorisation.

OR

- (iii) Solve the quadratic equation for x , using quadratic formula.



Chapter-05 Arithmetic Progression

- Q01. Aahana being a plant lover decides to convert her balcony into beautiful garden full of plants. She bought few plants with pots for her balcony. She placed the pots in such a way that number of pots in the first row is 2, second row is 5, third row is 8 and so on.

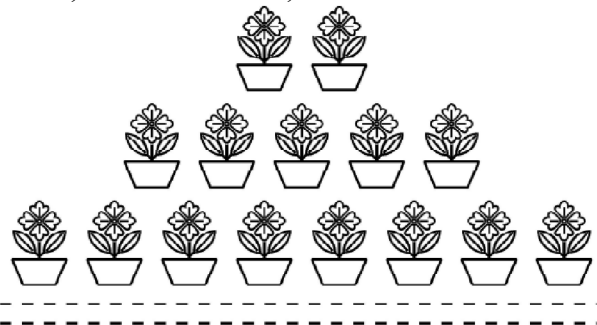

Based on the above information, answer the following questions.

- (i) Find the number of pots placed in the 10th row.
- (ii) Find the difference in the number of pots placed in 5th row and 2nd row.
- (iii) If Aahana wants to place 100 pots in total, then find the total number of rows formed in the arrangement.

OR

- (iii) If Aahana has sufficient space for 12 rows, then how many total number of pots are placed by her with the same arrangement?

- Q03. Treasure Hunt is an exciting and adventurous game where participants follow a series of clues / numbers / maps to discover hidden treasures. Players engage in a thrilling quest, solving puzzle and riddles to unveil the location of the coveted prize.

While playing a treasure hunt game, some clues (numbers) are hidden in various spots collectively forming an A.P. If the number on the n^{th} spot is $20 + 4n$, then answer the following questions to help the players in spotting the clues.

- (i) Which number is on first spot?
- (ii) Which spot is numbered as 112?

OR

- (ii) What is the sum of all the numbers on the first 10 spots?
- (iii) Which number is on the $(n - 2)^{\text{th}}$ spot?



- Q04. Saving money is a good habit and it should be inculcated in children right from the beginning. Rehan's mother brought a piggy bank for Rehan and puts one ₹5 coin of her savings in the piggy bank on the first day. She increases his savings by one ₹5 coin daily.



Based on the above information, answer the following questions.

- (i) How many coins were added to the piggy bank on 8th day?
- (ii) How much money will be there in the piggy bank after 8 days?
- (iii) If the piggy bank can hold one hundred twenty ₹5 coins in all, find the number of days she can contribute to put ₹5 coins into it.

OR

- (iii) Find the total money saved, when the piggy bank is full.

- Q05. While preparing for a competitive examination, Akbar came across a match-stick pattern based question. The pattern is given below.

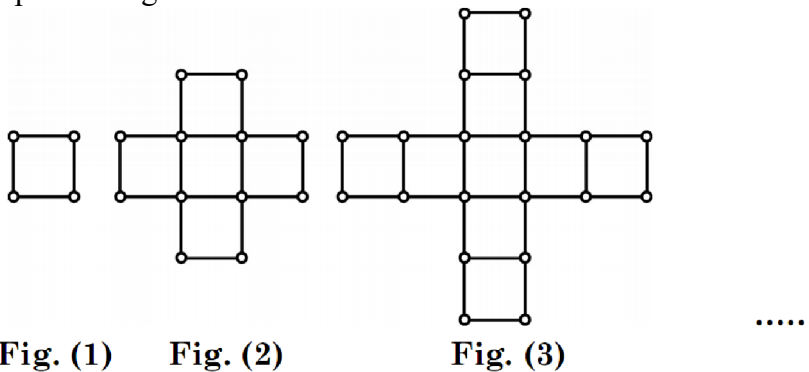

Fig. (1)

Fig. (2)

Fig. (3)

Based on the above information, answer the following questions.

- (i) Write first term and common difference of the A.P. formed by number of squares in each figure.
- (ii) Write first term and common difference of the A.P. formed by number of sticks used in each figure.
- (iii) How many squares are there in Fig. (10)? Also write the number of sticks used in Fig. (10).

OR

- (iii) If 88 sticks are used to make m^{th} figure [Fig. (m)], find the value of m. How many squares are formed in this figure?

- Q21. In the month of September to October 2022, the exports of electric bike from India increased by 25% in the corresponding quarter of 2021-22, as per a newspaper report.

A bike manufacturing company planned to produce 1000 bikes in fifth year and 1800 bikes in ninth year. Assume that the production increases uniformly by a fixed number every year.

- (i) Find the production in the first year.
- (ii) Find the production in the tenth year.
- (iii) Find the total production in first ten years.

OR

- (iii) In how many years will the total production reach 27200 bikes?



Chapter-06 Triangles

Q01. Observe the figures given below carefully and answer the questions.

Figure A

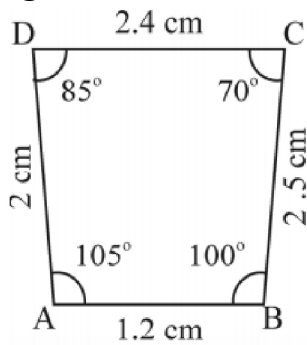

A (i)

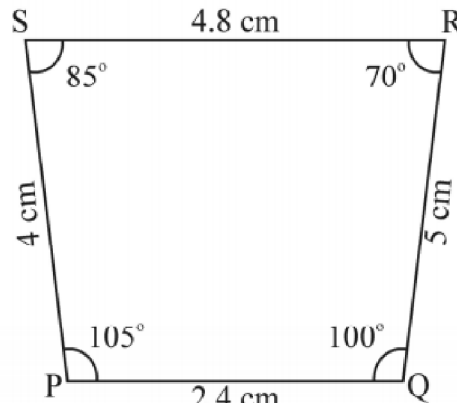

A (ii)

Figure B

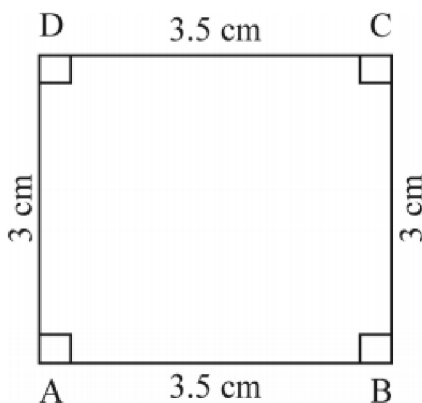

B (iii)

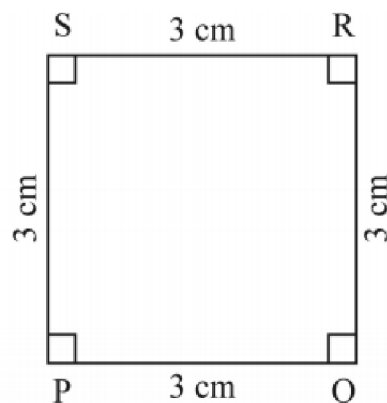

B (iv)

Figure C

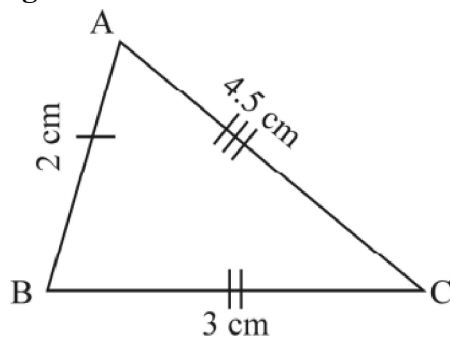

C (v)

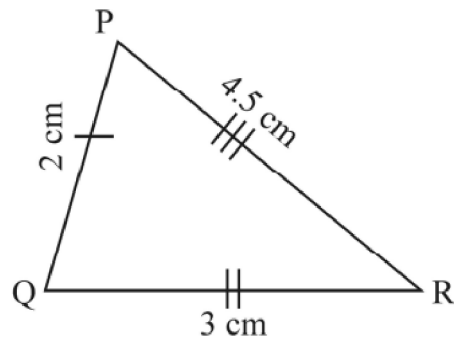

C (vi)

- (i) Name the figure (s) wherein two figures are similar.
- (ii) Name the figure (s) wherein the figures are congruent.
- (iii) Prove that congruent triangles are also similar but not the converse.

OR

- (iii) What more is least needed for two similar triangles to be congruent?

Chapter-07 Coordinate Geometry

Q01. Use of mobile screen for long hours makes your eye sight weak and give you headaches. Children who are addicted to play “PUBG” can get easily stressed out. To raise social awareness about ill effects of playing PUBG, a school decided to start ‘BAN PUBG’ campaign,

in which students are asked to prepare campaign board in the shape of a rectangle. One such campaign board made by class X student of the school is shown in the figure.

Based on the above information, answer the following questions.

- (i) Find the coordinates of the point of intersection of diagonals AC and BD.
- (ii) Find the length of the diagonal AC.
- (iii) Find the area of the campaign Board ABCD.

OR

- (iii) Find the ratio of the length of side AB to the length of the diagonal AC.

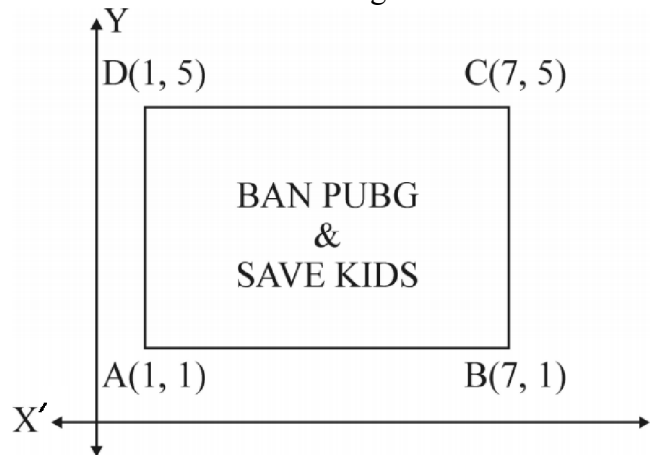

- Q03. Jagdish has a field which is in the shape of a right angled triangle AQC. He wants to leave a space in the form of a square PQRS inside the field for growing wheat and the remaining for growing vegetables (as shown in the figure). In the field, there is a pole marked as O.

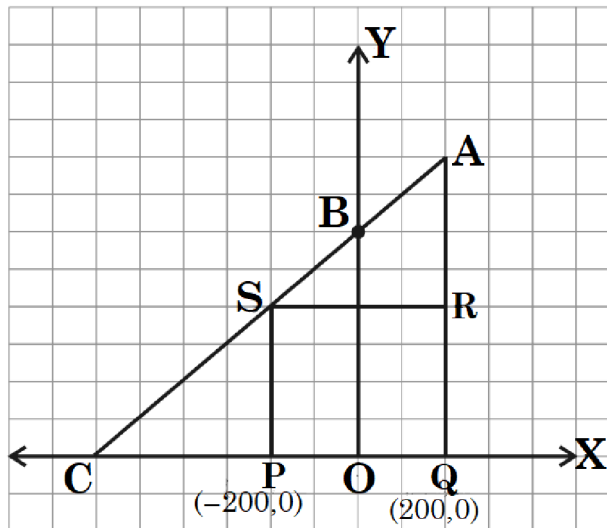

Based on the above information, answer the following questions.

- (i) Taking O as origin, coordinates of P are $(-200, 0)$ and of Q are $(200, 0)$. PQRS being a square, what are the coordinates of R and S?
- (ii) What is the area of square PQRS?

OR

- (ii) What is the length of diagonal PR in square PQRS?
- (iii) If S divides CA in the ratio $K:1$, what is the value of K, where point A is $(200, 800)$?

- Q25. Three persons A, B and C are sitting at $(3, 2)$, $(5, 6)$ and $(8, 1)$ respectively. Persons D, E and F are sitting at midpoints of AB, BC and CA respectively.

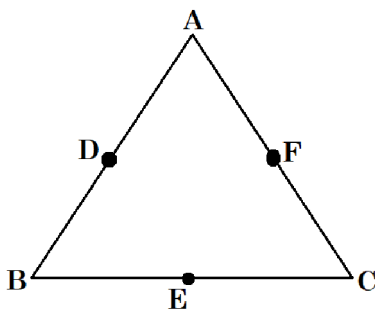

- (i) Find the distance between A and D.
- (ii) Find the distance between E and F.
- (iii) Find the coordinates of D, E and F.

OR

- (iii) Find the coordinates of point of intersection of AE, BF and CD.

Chapter-08 Introduction to Trigonometry

Q01. Mr Ajay helped his students learn about trigonometric ratios. He asked his students to draw a right-angled $\triangle ABC$, with hypotenuse (h) = 17, base (b) = 8 and perpendicular (p) = 15.

Using the information given above, answer the following questions.

- (i) Write the value of $\sin x$.
- (ii) Write the value of $\cos x$.
- (iii) Find the value of $\sec^2 x - \tan^2 x$.

OR

- (iii) Find the value of $\cot^2 x - \operatorname{cosec}^2 x$.

Chapter-09 Applications of Trigonometry

Q01. Radio towers are used for transmitting a range of communication services including radio and television. The tower will either act as an antenna itself or support one or more antennas on its structure. On a similar concept, a radio station tower was built in two Sections A and B. Tower is supported by wires from a point O.

Distance between the base of the tower and point O is 36 cm. From point O, the angle of elevation of the top of the Section B is 30° and the angle of elevation of the top of Section A is 45° .

Based on the above information, answer the following questions.

- (i) Find the length of the wire from the point O to the top of Section B.
- (ii) Find the distance AB.

OR

- (ii) Find the area of $\triangle OPB$.
- (iii) Find the height of the Section A from the base of the tower.

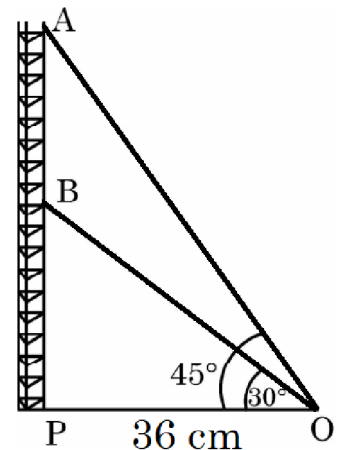

Q19. Two poles (AB and CD) of equal heights are standing opposite each other on either side of the road, which is 80 m wide. From a point O between them on the road, the angles of elevation of the top of the poles are 60° and 30° , respectively.

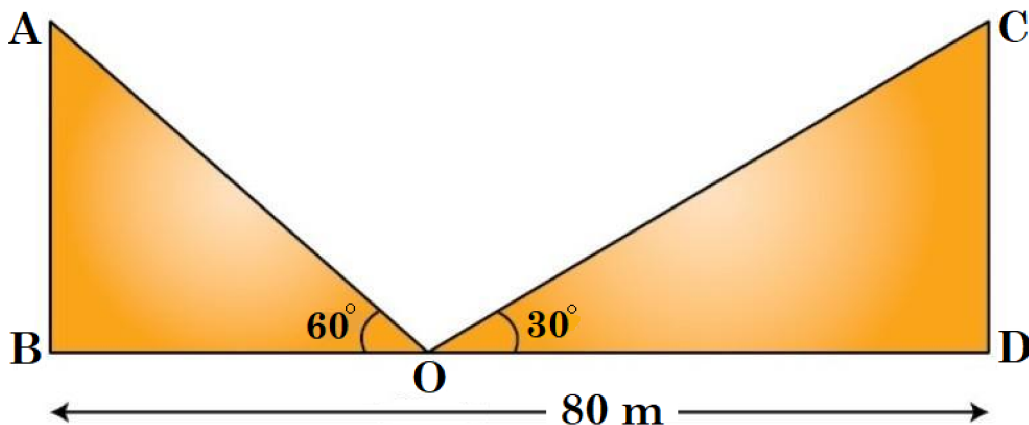

Answer the following questions, using the information given above.

- (i) Point O is closer to which pole?
- (ii) Find the distances of the point (O) from the poles.
- (iii) Find the height of each pole.

OR

- (iii) Find the ratio of height of pole to the distance of point from the closer pole.

Chapter-10 Circles

Q01. Circles play an important part in our life. When a circular object is hung on the wall with a cord at nail N, the cords NA and NB work like tangents. Observe the figure, given that $\angle ANO = 30^\circ$ and $OA = 5$ cm.

Based on the above information, answer the following questions.

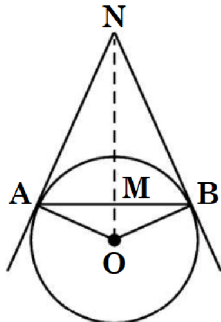

- (i) Find the distance AN.
- (ii) Find the measure of $\angle AOB$.
- (iii) Find the total length of cords NA, NB and the chord AB.

OR

- (iii) If $\angle ANO$ is 45° , then name the type of quadrilateral OANB. Justify your answer.

Q02. The discus throw is an event in which an athlete attempts to throw a discus. The athlete spins anti-clockwise around one and a half times through a circle, then releases the throw. When released, the discus travels along tangent to the circular spin orbit.

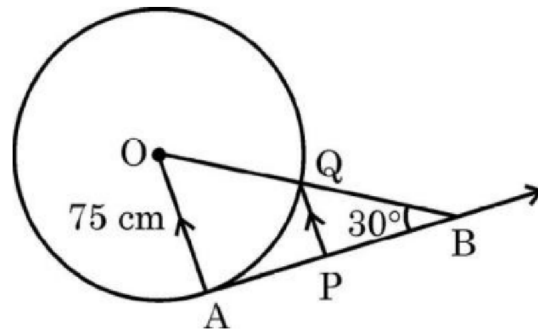
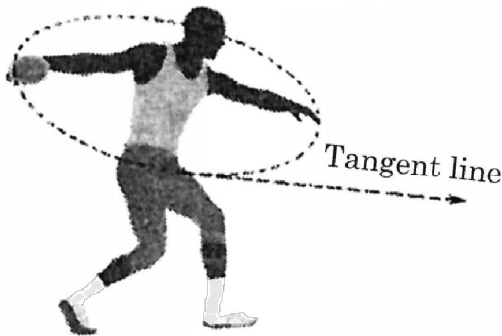

In the given figure, AB is one such tangent to a circle of radius 75 cm. Point O is centre of the circle and $\angle ABO = 30^\circ$. PQ is parallel to OA.

Based on the above information,

- (i) find the length of AB.
- (ii) find the length of OB.
- (iii) find the length of AP.

OR

- (iii) find the length of PQ.

Chapter-11 Areas Related to Circles

Q01. Interschool Rangoli Competition was organized by one of the reputed schools of Odissa. The theme of the Rangoli Competition was Diwali celebrations where students were supposed to make mathematical designs. Students from various schools participated and made beautiful Rangoli designs. One such design is given below.

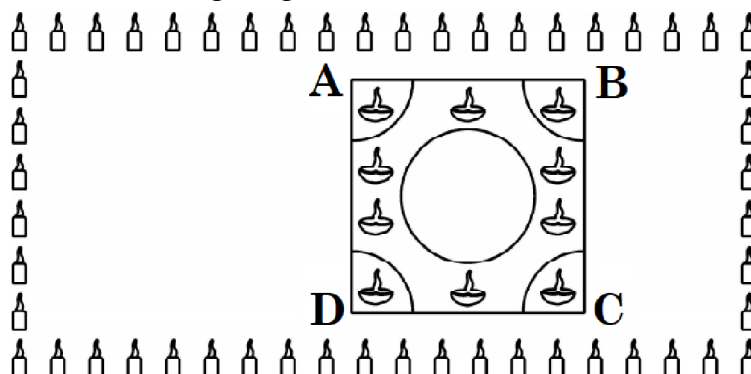

Rangoli is in the shape of square marked as ABCD, side of square being 40 cm. At each corner of a square, a quadrant of circle of radius 10 cm is drawn (in which diyas are kept). Also a circle of diameter 20 cm is drawn inside the square.

(i) What is the area of square ABCD?

(ii) Find the area of the circle.

(iii) If the circle and the four quadrants are cut off from the square ABCD and removed, then find the area of remaining portion of square ABCD.

OR

(iii) Find the combined area of 4 quadrants and the circle, removed.

Q08. NSS (National Service Scheme) aims to connect the students to the community and to involve them in problem solving process.

NSS symbol is based on the 'Rath' wheel of the Konark Sun Temple situated in Odisha. The wheel signifies the progress cycle of life.

The diagrammatic representation of the symbol is given below.

Observe the figure given here.

The diameters of inner circle are equally placed.

Given that $OP = 21$ cm, $OS = 10$ cm.

Based on the above information, answer the following questions.

(i) Find $m\angle ROS$.

(ii) Find the perimeter of sector OPQ.

(iii) Find the area of shaded region PQRS.

OR

(iii) Find the area of the shaded region ACB i.e., the segment ACB.

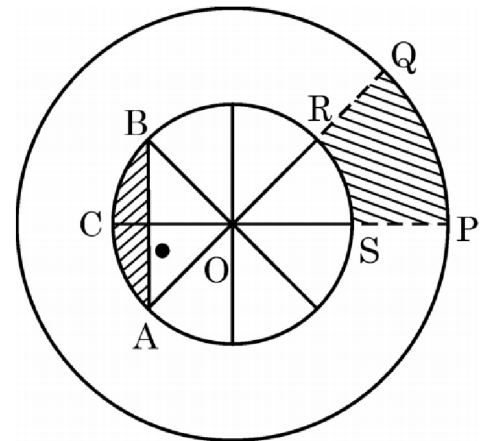

Chapter-12 Surface Areas and Volumes

Q01. A wooden toy is shown in the picture. This is a cuboidal wooden block of dimensions $14\text{ cm} \times 17\text{ cm} \times 4\text{ cm}$. On its top there are seven cylindrical hollows for bees to fit in. Each cylindrical hollow is of height 3 cm and radius 2 cm.



Based on the above, answer the following questions.

(i) Find the volume of wood carved out to make one cylindrical hollow.

(ii) Find the lateral surface area of the cuboid to paint it with green colour.

(iii) Find the volume of wood in the remaining cuboid after carving out seven cylindrical hollows.

OR

(iii) Find the surface area of the top surface of the cuboid to be painted yellow.

Chapter-13 Statistics

Q01. India meteorological department observes seasonal and annual rainfall every year in different sub-divisions of our country.



It helps them to compare and analyse the results.

The table given below shows sub-division wise seasonal (monsoon) rainfall (mm) in 2018.

Rainfall (mm)	Number of Sub-divisions
200-400	2
400-600	4
600-800	7
800-1000	4
1000-1200	2
1200-1400	3
1400-1600	1
1600-1800	1

Based on the above information, answer the following questions.

- (i) Write the modal class.
- (ii) Find the median of the given data.

OR

- (ii) Find the mean rainfall in this season.
- (iii) If sub-division having at least 1000 mm rainfall during monsoon season, is considered good rainfall sub-division, then how many sub-divisions had good rainfall?

Q06. **Mutual Fund** : A mutual fund is a type of investment vehicle that pools money from multiple investors to invest in securities like stocks, bonds or other securities. Mutual funds are operated by professional money managers, who allocate the fund’s assets and attempt to produce capital gains or income for the fund’s investors.

Net Asset Value (NAV) represents a fund’s per share market value. It is the price at which the investors buy fund shares from a fund company and sell them to a fund company.



The following table shows the Net Asset Value (NAV) per unit of mutual fund of ICICI mutual funds.

NAV (in ₹)	0-5	5-10	10-15	15-20	20-25
Number of mutual funds	13	16	22	18	11

Based on the above information, answer the following questions.

- (i) What is the upper limit of modal class of the data?
- (ii) What is the median class of the date?
- (iii) What is the mode NAV of mutual funds?

OR

- (iii) What is the median NAV of mutual funds?

Chapter-14 Probability

Q01. Blood group describes the type of blood a person has. It is a classification of blood based on the presence or absence of inherited antigenic substances on the surface of red blood cells. Blood types predict whether a serious reaction will occur in a blood transfusion.

In a sample of 50 people, 21 had type O blood, 22 had type A, 5 had type B and rest had type AB blood group.

Based on the above, answer the following questions.

- What is the probability that a person chosen at random had type O blood?
- What is the probability that a person chosen at random had type AB blood group?
- What is the probability that a person chosen at random had neither type A nor type B blood group?

OR

- What is the probability that person chosen at random had either type A or type B or type O blood group?

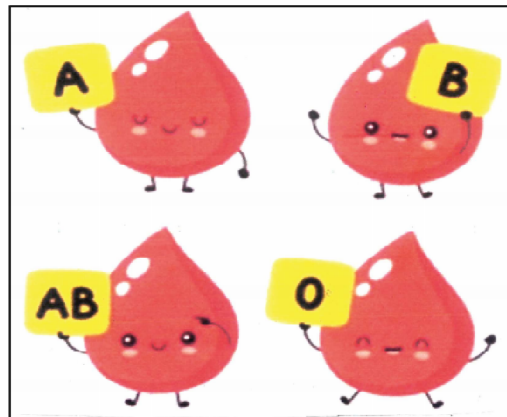

Q16. A family has 3 children. Assume each child is equally likely to be a boy or a girl. Consider all the possible combinations.



Find the probability that

- all are boys
- exactly one girl
- at least one boy

OR

- all are girls.



Scan the QR-Code to get our Maths books on Amazon

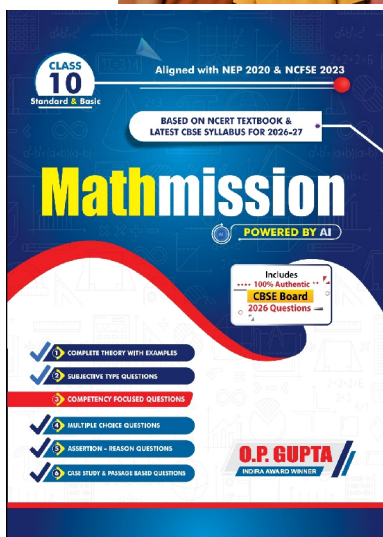

MATHMISSION FOR X (2026-27 Edition)

For CBSE Exams ▪ Maths (Standard & Basic)

By O.P. Gupta (Indira Award Winner)

- ✦ Detailed Theory with Examples
- ✦ Subjective type Questions (Chapter-wise : 2, 3 & 5 Markers)
- ✦ H.O.T.S. Questions

✦ COMPETENCY FOCUSED QUESTIONS

- ☑ Multiple Choices Questions (Chapter-wise)
- ☑ Assertion-Reason (A-R) Questions (Chapter-wise)
- ☑ Case Study / Passage Based Questions (Chapter-wise)

✦ ANSWERS & SOLUTIONS* of all Questions

① **SELECTED H.O.T.S. Questions from 2026 & 2025 Exams.**

✦✦ This FREE PDF is being shared to **HELP** teachers and students of class X.

We've added over 170 Case Study / Passage Based Questions in our **MATHMISSION FOR X** Book by O.P. GUPTA.

✦ **MATHMISSION** Books for Classes XII & XI are also available!

✦ You can buy our books on **Amazon / Flipkart** or, message us on WhatsApp @ **+919650350480**.

For Bulk order related queries at Discounted Price, Please contact by WhatsApp @ +91 9650350480 (only message)

CLASS

10

Standard & Basic

Aligned with NEP 2020 & NCFSE 2023

BASED ON NCERT TEXTBOOK &
LATEST CBSE SYLLABUS FOR 2026-27

Mathmission



POWERED BY AI

Includes

**** 100% Authentic **

CBSE Board

2026 Questions

1 COMPLETE THEORY WITH EXAMPLES

2 SUBJECTIVE TYPE QUESTIONS

3 COMPETENCY FOCUSED QUESTIONS

4 MULTIPLE CHOICE QUESTIONS

5 ASSERTION - REASON QUESTIONS

6 CASE STUDY & PASSAGE BASED QUESTIONS

O.P. GUPTA

INDIRA AWARD WINNER

BASED ON LATEST CBSE
SYLLABUS & NCERT TEXTBOOK
FULLY UPDATED FOR THE
SESSION 2026-27

POWERED BY



MATHMISSION

FOR X

MATHEMATICS
(Standard & Basic)

O.P. GUPTA

MATHS (H.), E & C ENGINEERING
INDIRA AWARD WINNER



Published by

MATHEMATICA

THE O.P. GUPTA ADVANCED MATH CLASSES
1st Floor of 1625 D 4/A, Opp. HP Petrol Pump, Thana
Road, Najafgarh, New Delhi-43

Third Edition

Latest 2026-27 Edition Based on New Pattern

Wednesday, March 25, 2026

© All Rights Reserved with O.P. Gupta
Copyright © Author

Price : ₹ 999/-

ISBN

978-93-340-8261-6

Printed by
Print Care, Delhi-110092

CAUTION

No part of this book or the complete book should be reproduced or copied in any form [photocopying, selling by any third party, resold, restored by information storage devices, or as the notes by any person(s)] without the prior consent of the author. Doing so will be considered as the intellectual theft and will deprive the author of his due credit for his work. Further if anyone is found sharing PDF of any portion of this Book via WhatsApp, Telegram or other digital / online mode without written consent of the author, s/he will be liable to face the relevant Indian laws.

REMARK

While we have taken all possible care in the editing, proof reading and printing of this book, still some errors might have crept in. The author should not be held responsible for any misprint/omission. We shall feel grateful for the suggestions received from the readers for the further improvement of the book.

Schools, Coaching Institutes
& Tutors may get **Discounted
Price for Bulk-orders** on our
Mathematics Books.

To know more, message on
WhatsApp @ +919650350480

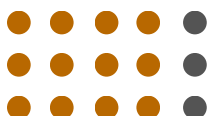

O.P. GUPTA

Math Mentor Indira Award Winner

OUR OTHER USEFUL PUBLICATIONS

- MATHMISSION FOR XII
- MATHMISSION FOR XI
- CBSE 39 SAMPLE PAPERS FOR XII
- CBSE YODDHA SAMPLE PAPERS FOR XI
- CBSE UMANG SAMPLE PAPERS FOR X
- NTA-CUET (UG) MATHS QUESTION BANK

MENTORS OF MATHMISSION

Mr Prabhat Marwaha

M.Sc. (Maths), B.Ed.
(37 Years Experience)
Former Principal, Jawahar Navodaya Vidyalaya,
Pipersand, Lucknow

Mr Pankaj Chugh

M.Sc. (Maths), M.Phil. (Maths), B.Ed.
(36 Years Experience)
DAV Public School, Paschim Vihar
Edu-Maths, Sec. 18, Rohini, Delhi

Dr Amit Bajaj

M.Sc. (Maths), M.A. (Education), B.Ed.
(26 Years Experience)
Senior Maths Faculty
CRPF Public School, Rohini, Delhi

Ms Ashita Mehta

M.Sc. (Maths), B.Ed.
(21 Years Experience)
PGT (Maths)
GD Goenka Public School, Indirapuram

WE ARE A TEAM

Mr Ajay Kumar Singh

Vice Principal, Jawahar Navodaya
Vidyalaya, Sirmour, Rewa
M.Sc., M.Phil., B.Ed., CSIR-UGC NET
Qualified in Mathematics

Ms Kanupreet Khanna

MA Economics, B.Ed.
(18 Years Experience)
TGT (Maths)
Sneh International School, Delhi

Mr Srihari Doddaka

M.Sc. (Maths), B.Ed.
(17 Years Experience)
HOD & PGT (Maths)
Narayana Educational Institutions,
Narayana E-Techno School, Chennai

Ms Priti Gupta

M.Sc. (Maths), B.Ed.
(29 Years Experience)
PGT (Maths)
Army Public School, Noida

Mr Vishal Minocha

B.A. (Maths), B.Ed., Dip. M.E.,
(28 Years Experience)
Vishal Institute, Sec. 3, Rohini

Ms Neenu Handa

M.Sc. (Maths)
(13 Years Experience)
TGT (Maths)
Seth Anandram Jaipuria School,
Vasundhara, Ghaziabad

Ms Sarabjeet Kaur

M.Sc. (Maths), MCA, B.Ed.
(26 Years Experience)
PGT (Maths)
Career+ Academy, Noida

Ms Heena Arya

M.Sc. (Maths), B.Ed.
(11 Years Experience)
PGT (Maths)
Dynasty International School, Faridabad

Mr Sachin Pandey

M.Sc. (Maths), B.Ed.
(19 Years Experience)
PGT Maths & Coordinator
St. Mary's Sr. Sec. School,
Rudrapur, Uttarakhand

Ms Daljeet Kaur

M.Phil. (Maths)
(21 Years Experience)
PGT (Maths)
Morning Star St. Anslem's Sr. Sec.
School, Jaipur

Ms Dharini Dave

B.E., M.Sc. (Maths), B.Ed.
(11 Years Experience)
PGT (Maths)
Countryside International
School, Surat

Following are the Books for CBSE XII, XI & X (2026-27) by O.P. Gupta.

 **MATHMISSION FOR XII, XI & X (Latest Edition)**

For CBSE 2027 Exams ▪ Maths (041)

By **O.P. Gupta (Indira Award Winner)**

- ✦ Detailed Theory with Examples
- ✦ Subjective type Questions (Chapter-wise : 2, 3 & 5 Markers)
- ✦ H.O.T.S. Questions from recent CBSE 2026 & 2025 Exams
- ✦ **COMPETENCY FOCUSED QUESTIONS**
 - ☑ Multiple Choices Questions (Chapter-wise)
 - ☑ Assertion-Reason (A-R) Questions (Chapter-wise)
 - ☑ Case Study / Passage Based Questions (Chapter-wise)
- ✦ **ANSWERS** of all Questions

 **SOLUTIONS OF MATHMISSION FOR XII & XI (Latest Edition)**

For CBSE 2027 Exams ▪ Maths (041)

By **O.P. Gupta (Indira Award Winner)**

- ✦ **Step-by-Step Detailed Solutions of all the Exercises of MATHMISSION FOR XII & XI**

① Books are available on Amazon / Flipkart / Theopgupta.com
For **Discounted Price**, order on WhatsApp @ +919650350480.

 This is only a **Demo sample file** of MATHMISSION FOR X (2026-27).
The contents shown in this Document are just glimpses of what we have provided in the Printed book.

 **You may Share this Document with any class X Student and Teacher.**

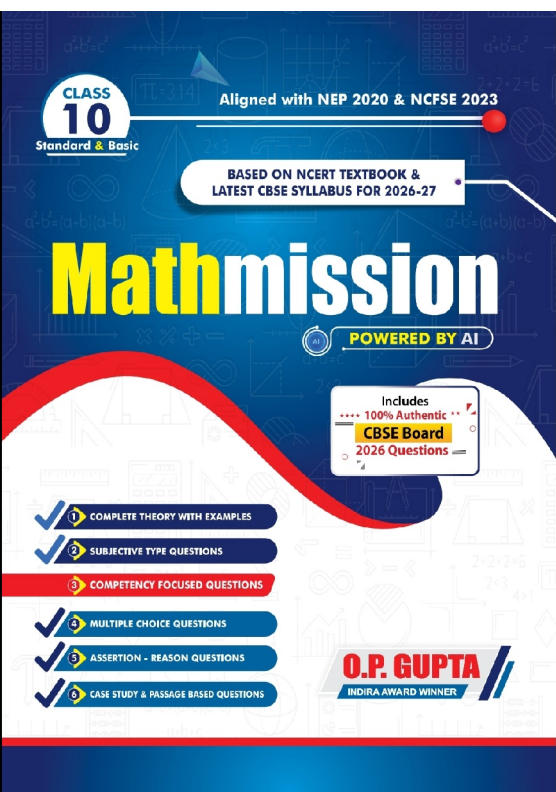

A BRIEF SYNOPSIS Of CONTENTS IN

MATHMISSION FOR X

For CBSE 2026-27 Exams
(Maths - Standard & Basic)

By O.P. Gupta
Indira Award Winner

- ★ Detailed Theory with Examples
- ★ Subjective type Questions (2, 3 & 5 Markers)
- ★ H.O.T.S. Questions from recent CBSE 2026 & 2025 Exams
- ★ COMPETENCY FOCUSED QUESTIONS
 - ☑ Multiple Choices Questions (Chapter-wise)
 - ☑ Assertion-Reason (A-R) Questions (Chapter-wise)
 - ☑ Case Study / Passage Based Questions (Chapter-wise)
- ★ ANSWERS of all Questions

MATHMISSION Books are also available for the Classes XII & XI.

◆ Books are available on **Amazon / Flipkart**.

📖 For latest Math-Lectures, visit on
YouTube.com/@theopgupta

For order related queries, please contact on
WhatsApp @ +91 9650350480 (only message)

Discounted price available for Bulk orders.

SHARE WITH TEACHERS & STUDENTS ALSO TO HELP THEM IN THEIR PREPARATION

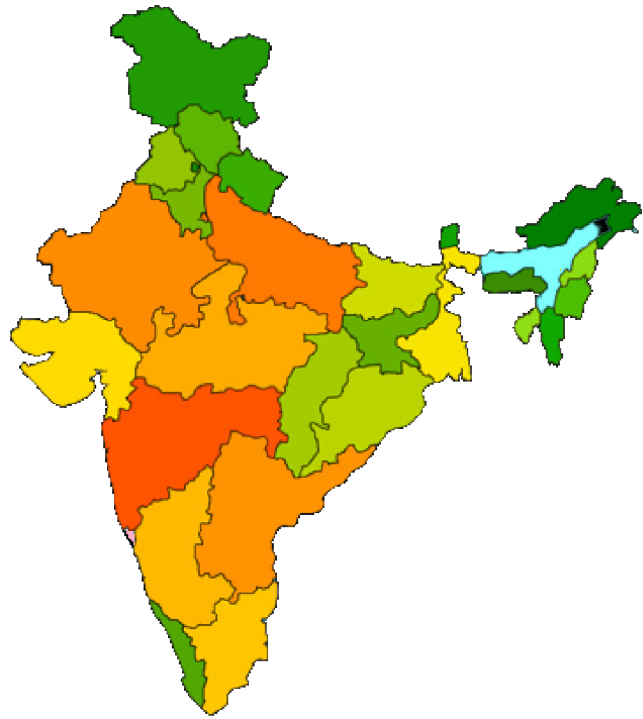

OUR BOOKS HAVE GONE TO VARIOUS STATES OF INDIA & ABROAD

- Jammu & Kashmir
- Himachal Pradesh
- Punjab
- Chandigarh
- Rajasthan
- Delhi
- Haryana
- Uttarakhand
- Uttar Pradesh
- Bihar
- Jharkhand
- Odisha
- West Bengal
- Goa

- Assam
- Tripura
- Madhya Pradesh
- Chhattisgarh
- Gujarat
- Telangana
- Andhra Pradesh
- Maharashtra
- Karnataka
- Tamilnadu
- Kerala
- Puducherry
- Andaman & Nicobar Islands
- Daman & Diu

MATHMISSION @ FOREIGN LOCATIONS

- Oman
- Doha (Qatar)
- Saudi Arabia
- Dubai
- Singapore



MATHEMATICIA BY O.P. GUPTA

...a name you can bank upon!



Feel Safe to **Share this Document** with other math scholars

CLICK NOW

TO Download



**FREE PDF TESTS AND
ASSIGNMENTS OF THE
CLASSES XII, XI & X**

or, just type -
theopgupta.com

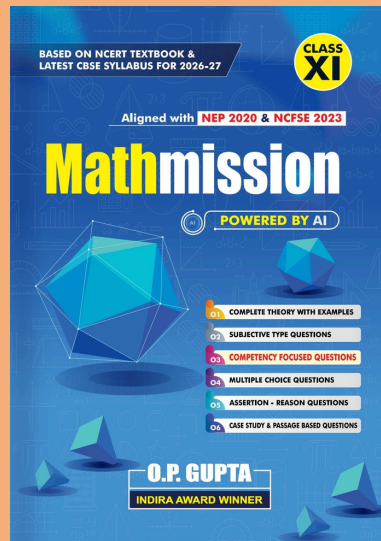
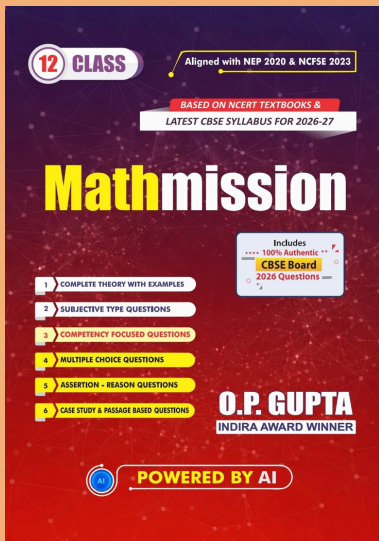

Click on the
Book cover
to buy!



Many **Direct Questions**
from our **Books** have
been asked frequently in
the recent **CBSE Exams**.

Latest 2026-27 Edition
**MATHMISSION
FOR XII, XI & X**
By **O.P. GUPTA**

Buy our
books on
amazon
Flipkart

Join Our Mathematics Learning & Teachers Community

To support **collaborative learning and resource sharing** in Mathematics, dedicated WhatsApp groups have been created for:

Maths Teachers Community	Students of Classes XI & XII	Students of Classes IX & X
		

These groups aim to share:

- ✓ Quality Mathematics Resources
- ✓ Board Exam Discussions & Solutions
- ✓ Important Practice Questions & Updates
- ✓ Healthy Academic Interaction

① How to Join?

Please **scan the QR-Code** corresponding to your category (Teachers / Class IX - X Students / Class XI - XII Students) to join the relevant group.

Alternatively, you can **touch the QR-Code** too, after opening in the Drive PDF App.

✪ Important Guidelines

- Teachers are requested NOT to join student groups.
 - Students are requested NOT to join teachers' groups.
- ☑ If you are already a member of any of our existing groups, please avoid joining another group to prevent repeated notifications of the same resources.
Instead, you may share this opportunity with your colleagues or students who may benefit from these Mathematics learning communities.

With Regards

O.P. Gupta

Author - Mathmission Series of Books

Founder & Mentor

THE O.P. GUPTA ADVANCED MATH CLASSES

@ Thana Road, Najafgarh, New Delhi

■ WhatsApp: +91 9650350480



Dedicated to helping students and teachers strengthen conceptual understanding and excel in Mathematics.



ABOUT THE AUTHOR

O.P. GUPTA having taught math passionately over a decade, has devoted himself to this subject. Every book, study material or practice sheets, tests he has written, tries to teach serious math in a way that allows the students to learn math without being afraid. Undoubtedly his mathematics books are best sellers on [amazon](#) and [Flipkart](#).

His resources have helped students and teachers for a long time across the country. He has contributed in CBSE Question Bank (issued in April 2021). Mr Gupta has been invited by many educational institutions for hosting sessions for the students of senior classes. Being qualified as an electronics & communications engineer, he has pursued his graduation later on with mathematics from University of Delhi due to his passion towards mathematics. He has been honored with the prestigious INDIRA AWARD by the Govt. of Delhi for excellence in education.

MOST REPUTED MATHEMATICS BOOKS

MATHMISSION & SOLUTIONS

CLASS 12



CLASS 11



CLASS 10



Our All-inclusive Refresher-guide Feature



- ✓ Theory & Examples
- ✓ Subjective Questions



- ✓ Multiple Choice Questions
- ✓ Assertion Reason Questions



- ✓ Case Study Questions
- ✓ Answers for Exercises



- ✓ Detailed Step-by-step Solutions
- ✓ QR-Codes for more Resources

MOST TRUSTED SAMPLE PAPERS & CUET Practice Book

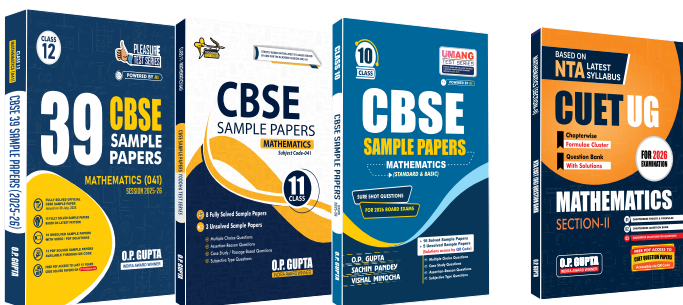

Our popular Sample Papers Guides feature

- Official CBSE Sample Papers with Solutions
- Plenty of Fully Solved Sample Papers
- Different Levels of Sample Papers
- Unsolved Sample Papers for Practice

MATH – Lectures, Tests, Sample Papers...
Queries Regarding Maths?

Feel free to contact us
✉ iMathematicia@gmail.com
☎ +919650350480 (Message only)



Visit our YouTube Channel

MATHEMATICIA BY O.P. GUPTA

FREE PDF
DOWNLOADS



theopgupta.com

CBSE Board Papers, Sample papers,
Topic Tests, Assignments & More...



BUY OUR BOOKS ONLINE

[amazon](#) [Flipkart](#) [f](#)

